

# REVEAL™ 1192

LIFT COFFEE TABLE

## INSTRUCTION MANUAL

**LET'S GET STARTED.**

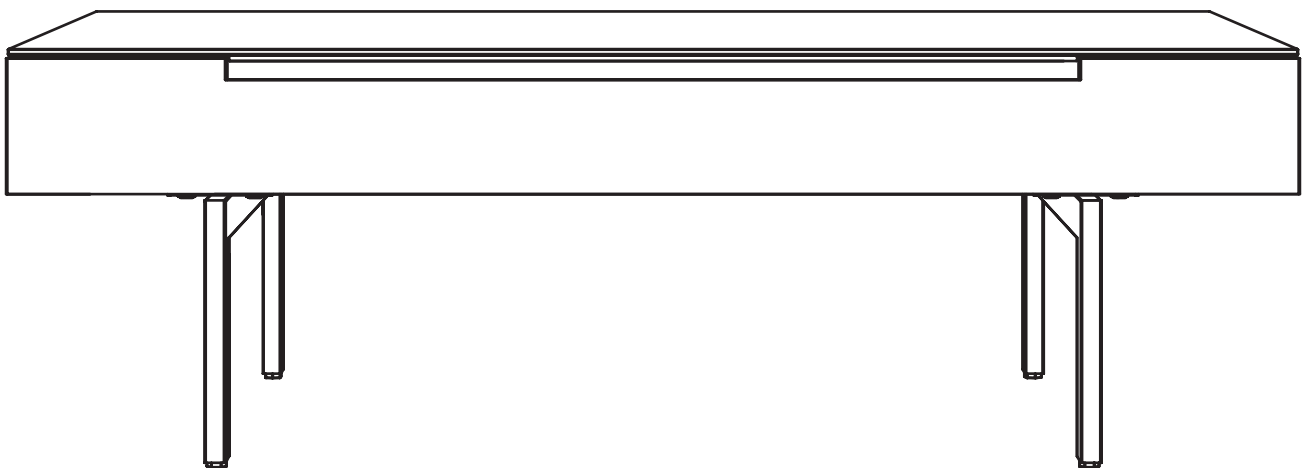

DESIGN MATTHEW WEATHERLY

**BDi**

BDIUSA.COM



Congratulations on the purchase of your Reveal Lift Coffee Table 1192 from BDI. Your coffee table has been designed to provide a lifetime of enjoyment. This manual will provide you with assembly instructions and other helpful information to ensure that you get the most out of your product. Please save it for future reference.

Your Reveal Lift Coffee Table has been engineered for simple assembly. Please follow these directions carefully to prevent any damage.

Should you need further assistance, contact BDI at [customerservice@bdiusa.com](mailto:customerservice@bdiusa.com).

ENJOY!

## HARDWARE AND COMPONENTS

Unpack and identify the parts listed below. The assembly workspace should be a non-marring surface such as carpet. For missing hardware pieces, please contact BDI Customer Service at [customerservice@bdiusa.com](mailto:customerservice@bdiusa.com).

Do not use power tools for the assembly of this product.

For all other concerns, please contact your BDI retailer.



PART #	<b>T1</b>
DESCRIPTION	Hex Wrench
QUANTITY	1

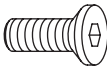

PART #	<b>H1</b>
DESCRIPTION	M6 x 16mm Countersunk Screw
QUANTITY	8

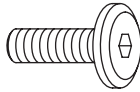

PART #	<b>H2</b>
DESCRIPTION	M6 x 16mm Screw
QUANTITY	16

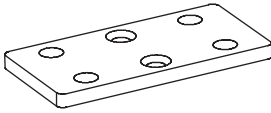

PART #	<b>C1</b>
DESCRIPTION	Leg Plate
QUANTITY	4

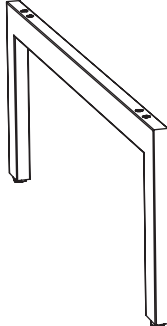

PART #	<b>C2</b>
DESCRIPTION	Leg
QUANTITY	2

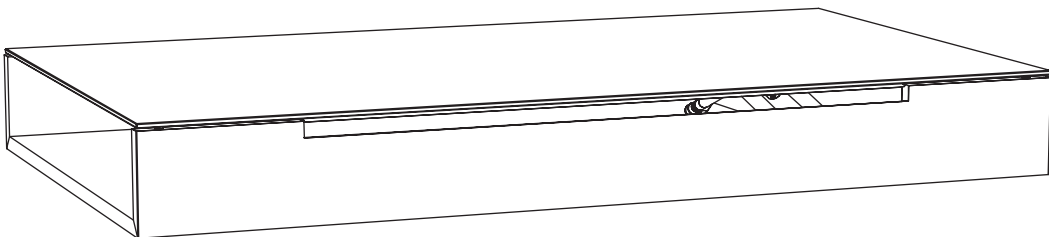

PART #	<b>C3</b>
DESCRIPTION	Cabinet
QUANTITY	1

## STEP 1. REMOVE CARDBOARD END CAPS

## ASSEMBLY

Making sure the glass tabletop is facing up, remove the cardboard end caps and microfilm.

**IMPORTANT! Save the end caps. Open the glass lid by lifting and pulling forward. Remove the inner carton. Close the tabletop.**

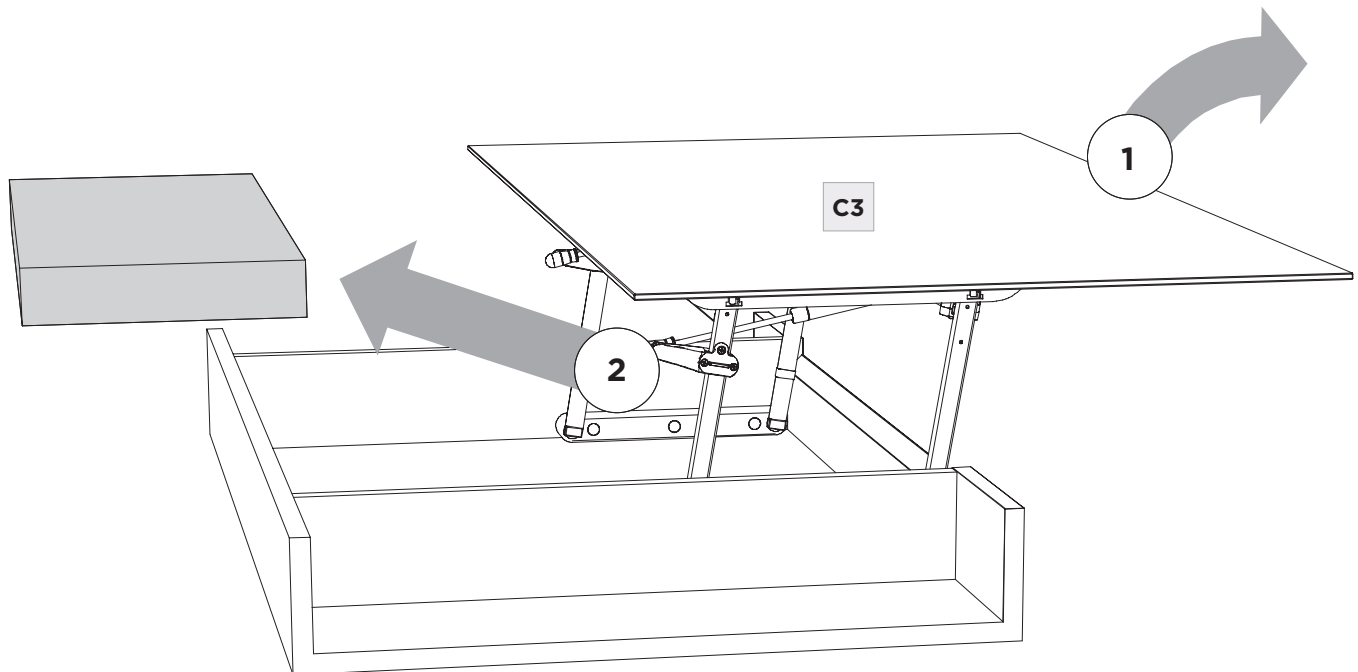

Place cardboard end caps back onto the ends of the **(C3) Cabinet**.

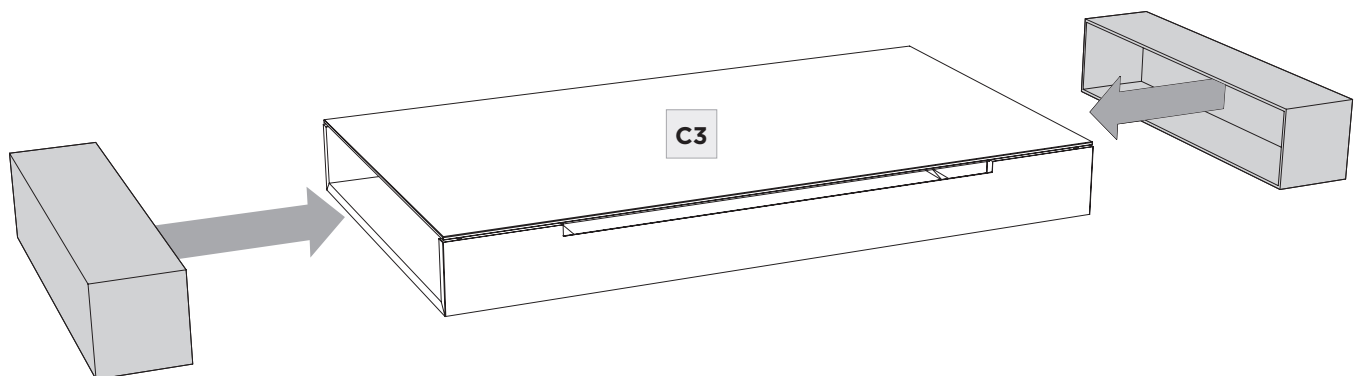

Attach two **(C1) Leg Plates** to the tops of the **(C2) Legs** using **(H1) Screws**. Make sure the countersink is facing away from the leg. Tighten with **(T1) Hex Wrench**.

	PART/DESCRIPTION	QTY
	T1-HEX WRENCH	1
	H1-SCREW	8

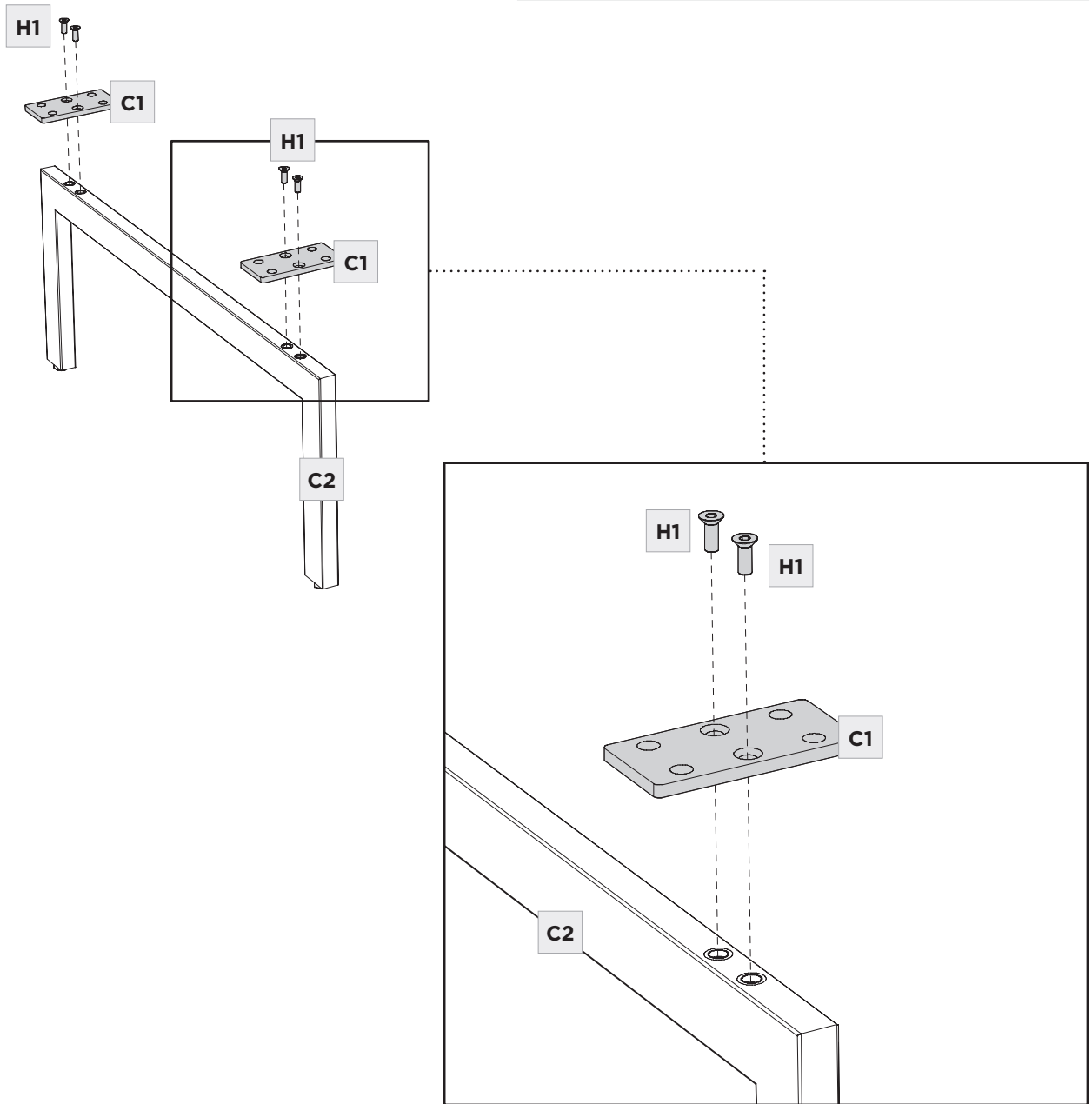

### STEP 3. ATTACH LEGS

2 PERSON TASK



ASSEMBLY

With help from another person, carefully rotate **(C3) Cabinet** onto its back, making sure that the cardboard end caps stay in place (to prevent the tabletop from opening by itself).

Attach both **Legs** as shown using **16 (H2) Screws**. Start all of the **(H2) Screws** before fully tightening with **(T1) Hex Wrench**.

	PART/DESCRIPTION	QTY
	T1-HEX WRENCH	1
	H2-SCREW	16

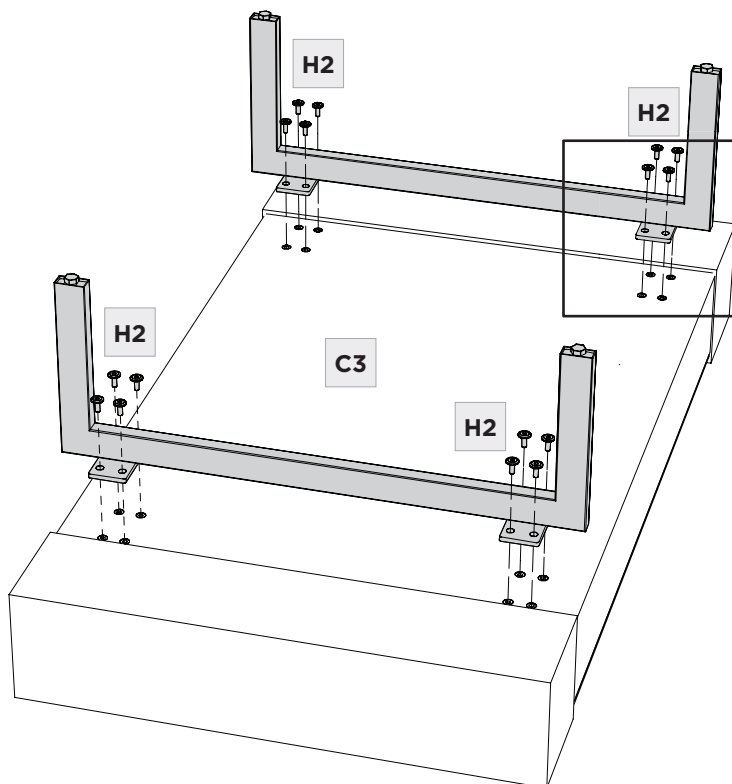
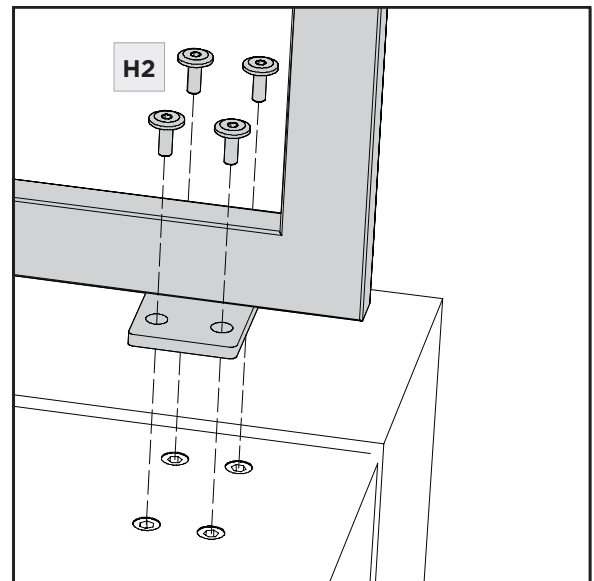



With help from another person, carefully rotate the **(C3) Cabinet** onto its base, ensuring that the cardboard endcaps stay in place.

Now, remove both of the end caps.

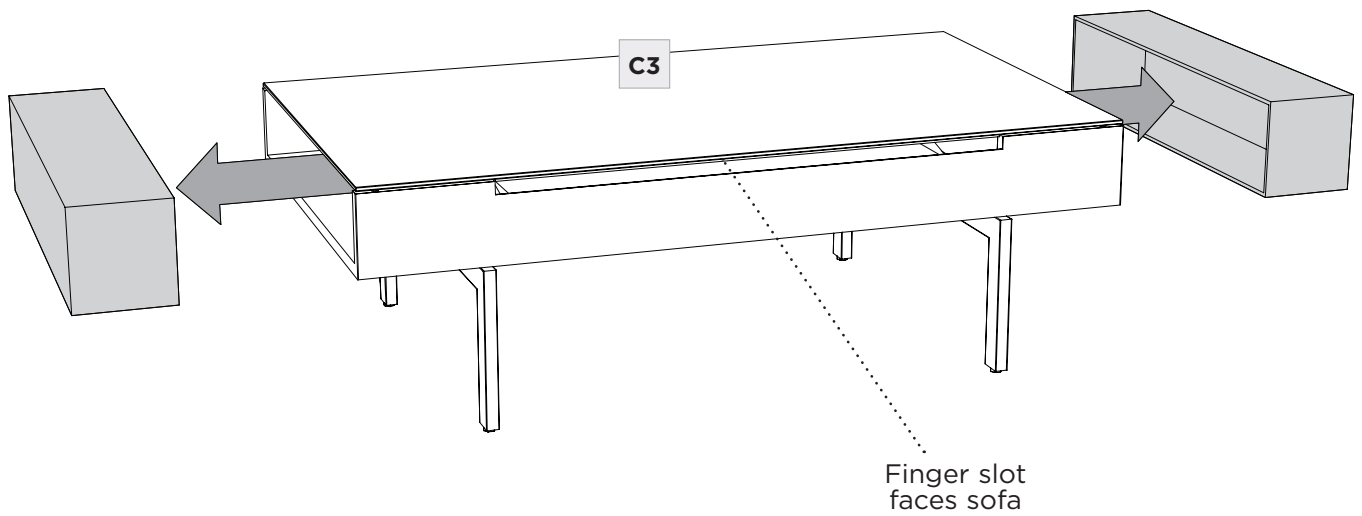

**CAUTION! Do not move the table with the tabletop in its extended position.**

Moving the table by its base is recommended.

Position the table approximately 12"-14" away from your sofa with the finger slot facing the opening direction. Using the finger pull located along the tabletop's underside, pull the tabletop to its fully extended position.

If required, use the levelers to make adjustments to the table's base.

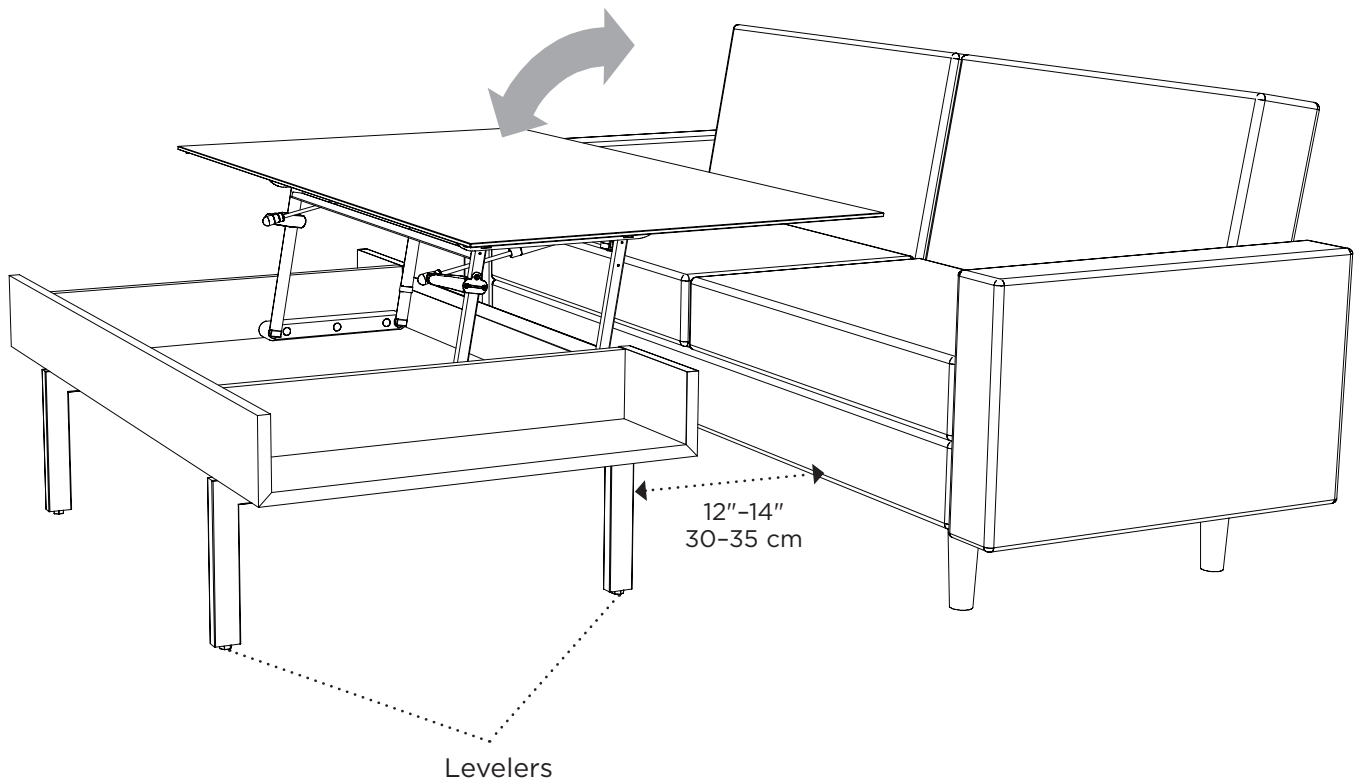

## CAUTION

### TABLE TOP LOAD CAPACITY

OPEN: 30 lbs

CLOSED: 100 lbs

## CARE & MAINTENANCE

### GLASS

The glass surface is maintained using household glass cleaner and a paper towel or cloth.

### SATIN-ETCHED GLASS

This uniquely smooth-to-the-touch glass surface can be regularly maintained using household glass cleaner and a paper towel or cloth. Minor scratches or scuffs not eliminated using paper towel or cloth can usually be removed by using a 'Magic Eraser'. Magic Eraser is a melamine foam product available at any grocery store or home improvement center. Dampen the entire glass surface and the Magic Eraser, then rub the entire glass surface in broad, even strokes using moderate pressure. Clean and dry the surface with a paper towel. Check for results and repeat as necessary.

Any scratches or scuffing not eliminated by one of the above methods can often be addressed by 'refreshing' the glass. This is a process that should not be required more than once per 6-12 months. See this brief video for the simple method: [www.bdiusa.com/glass](http://www.bdiusa.com/glass)

### WOOD

Wood surfaces should be cleaned with a slightly damp (not saturated) cloth or paper towel. Do not use glass cleaner on wood. If moisture remains, dry the surface with another cloth. If needed, a gentle non-abrasive cleanser may be used, but be sure to wipe away all cleaner residue and dry the surface with a cloth.

BDI's wood finishes feature natural hardwood solids and veneers. Wood is a product of nature and—unlike man-made materials that can be manufactured to strict and consistent specifications—has natural imperfections that are part of its appeal and character. Every piece of wood differs from every other, even when coming from the very same tree. As such, variation in grain, texture and tone should be expected from one panel or piece of furniture to the next.

While BDI's stained wood finishes are stable in tone & appearance, all finishes are subject to some degree of discoloration with prolonged exposure to direct sunlight. Please take care to avoid positioning your BDI cabinet in any area with extensive direct sunlight. To learn more about the features of natural wood, visit [www.bdiusa.com/wood](http://www.bdiusa.com/wood)

### METAL & PAINTED SURFACES

Surfaces should be cleaned with a slightly damp (not saturated) cloth or paper towel. If moisture remains, dry the surface with another cloth. If needed, a gentle non-abrasive cleanser may be used, but be sure to wipe away all cleaner residue and dry the surface with a cloth.

## WARRANTY

BDI warrants to the original purchaser that for the below-stated warranty term, BDI will repair or replace any product, part, or component covered by this warranty that fails under normal use as a result of a defect in material or workmanship. BDI will repair or replace the aforementioned product, part or component with a comparable product, part or component. The decision to repair or replace will be at BDI's sole discretion.

BDI Home Theater Furniture, Office Furniture, Modular Systems, Tables, and other furniture pieces are warranted for three (3) years from the date of purchase as shown on your sales receipt. The warranty period starts from the date of purchase. This warranty extends only to the original purchasers who acquire new products from BDI Authorized Resellers. Any product, part, or component must have been assembled, installed, used, and maintained according to BDI's published instructions to be eligible for warranty coverage. Any modification to the original product voids the warranty.

To view BDI's complete warranty information, visit [www.bdiusa.com/warranty](http://www.bdiusa.com/warranty)

## PRODUCT REGISTRATION

Registering your new BDI product allows us to send you important product updates, service information, and helpful hints related to your BDI products. Register today, and you will be entered to win free a BINK table from BDI: [www.bdiusa.com/register](http://www.bdiusa.com/register)



**BDIUSA.COM**

These distinctive product configurations are protected by US and international patents, trade dress, and/or copyright laws. Reveal & BDI are trademarks of Becker Designed, Inc. All rights reserved. ©2021, BDI | V.05.13.2021

Made in Turkey.