

SEQUEL[®] 20 6117

MULTIFUNCTION CABINET

INSTRUCTION MANUAL

LET'S GET STARTED.

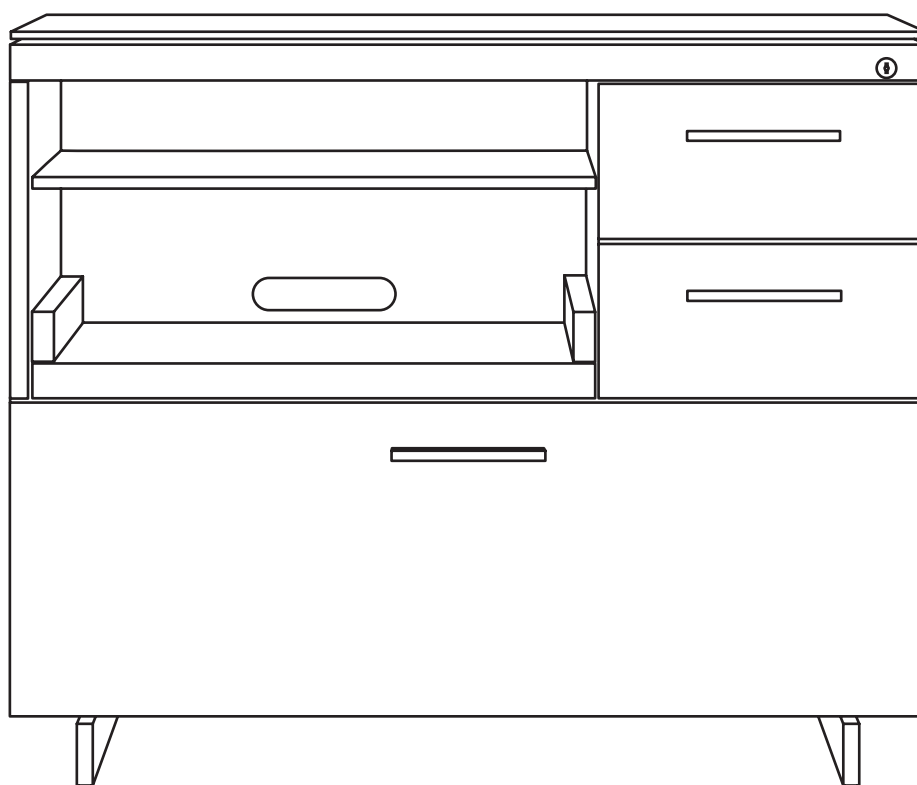

DESIGN MATTHEW WEATHERLY

BDi

BDIUSA.COM



Congratulations on the purchase of your Sequel 20 Multifunction Cabinet 6117 from BDI. Your file cabinet has been designed to provide a lifetime of enjoyment. This manual will provide you with assembly instructions and other helpful information that will ensure that you get the most out of your cabinet. Please save it for future reference.

Your Sequel 20 Multifunction cabinet has been engineered for simple assembly. Please follow these directions carefully to prevent any damage.

Should you need further assistance, contact BDI at customerservice@bdiusa.com.

ENJOY!

HARDWARE AND COMPONENTS

Unpack and identify the parts listed below. The assembly workspace should be a non-marring surface such as carpet. For missing hardware pieces, please contact BDI Customer Service at customerservice@bdiusa.com.

Do not use power tools for assembly of this product.

For all other concerns, please contact your BDI retailer.

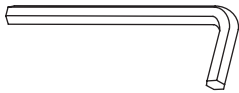

PART #	T1
DESCRIPTION	Hex Wrench
QUANTITY	1

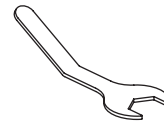

PART #	T2
DESCRIPTION	Leveler Wrench
QUANTITY	1



PART #	H1
DESCRIPTION	Flat Head M6 Screw
QUANTITY	8



PART #	H2
DESCRIPTION	Button Head M6 Screw
QUANTITY	16

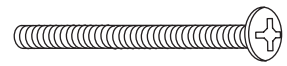

PART #	H3
DESCRIPTION	M4 x 35mm Screw
QUANTITY	6

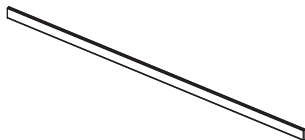

PART #	H4
DESCRIPTION	Small File Bar
QUANTITY	2



PART #	H5
DESCRIPTION	File Bar Clip
QUANTITY	6

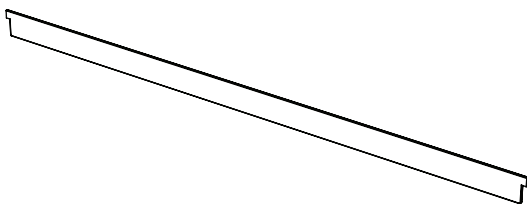

PART #	H6
DESCRIPTION	Long File Bar
QUANTITY	1

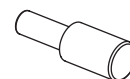

PART #	H7
DESCRIPTION	Push-in Shelf Pin
QUANTITY	4

HARDWARE AND COMPONENTS

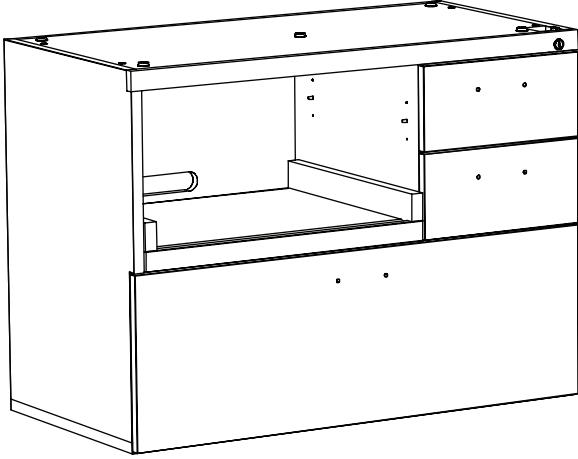

PART #	C1
DESCRIPTION	Cabinet
QUANTITY	1

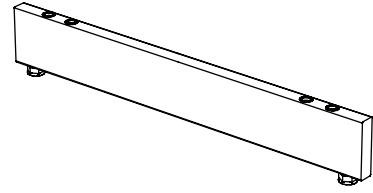

PART #	C2
DESCRIPTION	Leg
QUANTITY	2

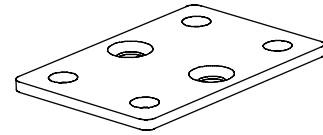

PART #	C3
DESCRIPTION	Leg Plate
QUANTITY	4

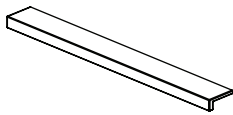

PART #	C4
DESCRIPTION	Drawer Pull
QUANTITY	3



PART #	C5
DESCRIPTION	Adjustable Shelf
QUANTITY	1



PART #	C6
DESCRIPTION	Glass Top Panel
QUANTITY	1



TOOL REQUIRED (NOT INCLUDED)



Phillips Screwdriver

ASSEMBLY

STEP 1. ATTACH THE LEG PLATES

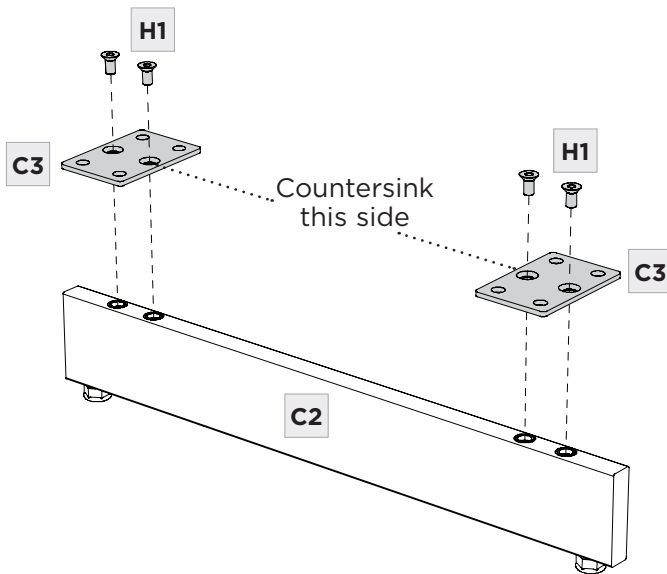
Attach **(C3) Leg Plates** to **(C2) Legs** using **(H1) Flathead Screws** and **(T1) Hex Wrench**. Make sure the countersink is on top.



	PART/DESCRIPTION	QTY
	T1-HEX WRENCH	1
	H1-FLATHEAD SCREW	8

ASSEMBLY



STEP 2. ATTACH THE LEGS

2 PERSON TASK

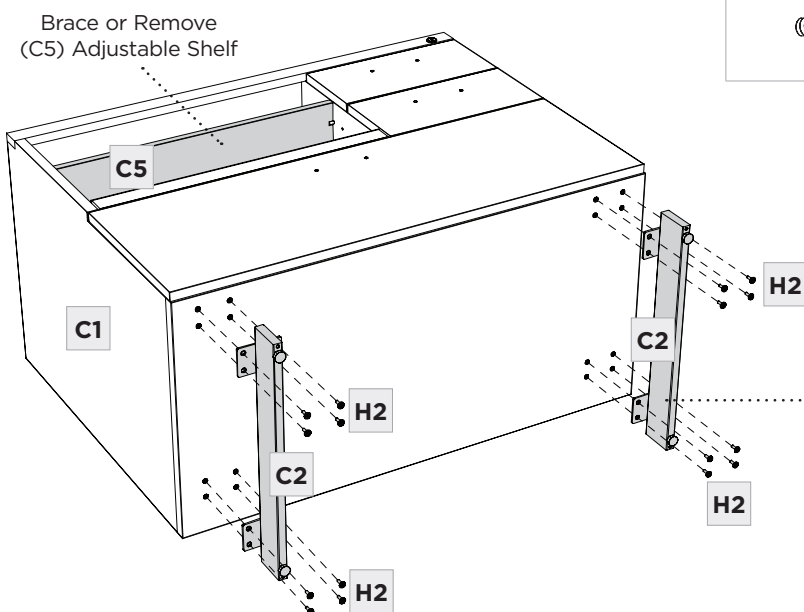

Make sure **(C5) Adjustable Shelf** is still held in place with packing material (or removed from the **(C1) Cabinet**). Carefully position **(C1) Cabinet** onto its back. Install **(C2) Leg Frames** using **(H2) Screws** and **(T1) Hex Wrench**.



	PART/DESCRIPTION	QTY
	T1-HEX WRENCH	1
	H2-SCREW	16

STEP 3. PLACE GLASS TOP

2 PERSON TASK

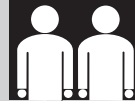

ASSEMBLY

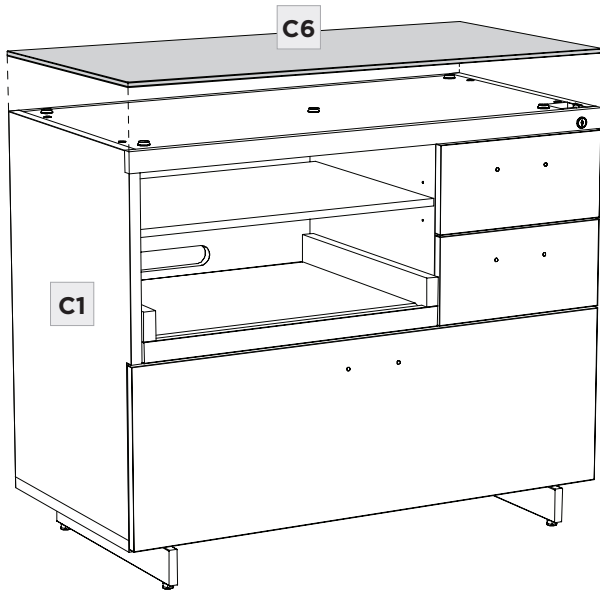

With help from another person, carefully lift the cabinet onto its base. Place **(C6) Glass Top Panel** into position on top of the **(C1) Cabinet**. Align all edges. The glass edge should be offset 1.5mm from the side of the cabinet on all 4 sides.

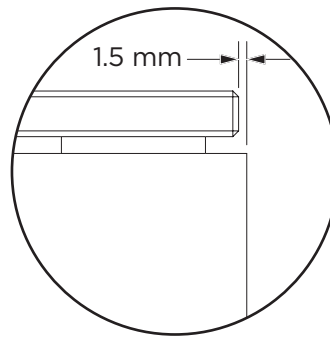



STEP 4. ATTACH DRAWER PULLS

ASSEMBLY

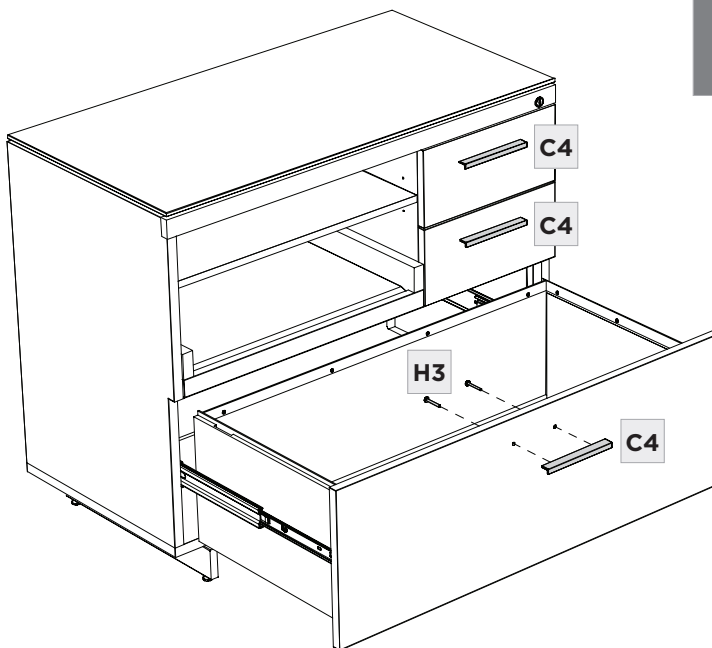
Open a drawer and connect a **(C4) Drawer Pull** using **2 (H3) Screws**. Tighten with a **Phillips Screwdriver** (not included). Install the other **2 (C4) Drawer Pulls** one at a time.



	PART/DESCRIPTION	QTY
	H3-Screw	6
	NOT INCLUDED Phillips Screwdriver	1

FINE TUNING

ADJUSTABLE SHELF

Install the **(C5) Adjustable Shelf**. You may adjust the position of the **(C5) Adjustable Shelf** by pulling the 4 shelf pins out and relocating them.

LEVEL CABINET

Make sure the **(C1) Cabinet** is level. Adjust 1 or more of the levelers using **(T2) Leveler Wrench** to attain a level stance.

	PART/DESCRIPTION	QTY
	T2-Leveler Wrench	1

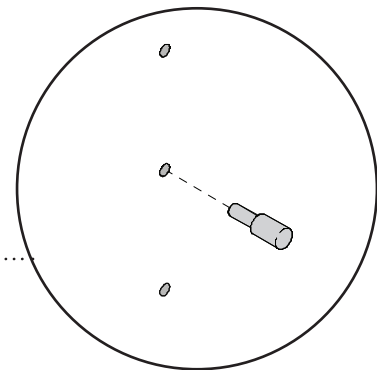
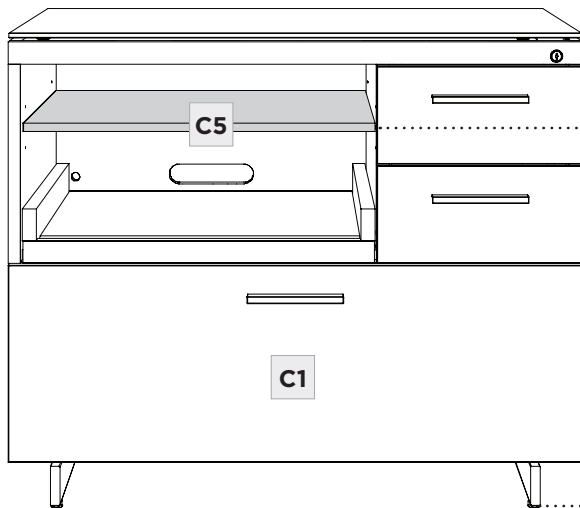

Shelf pins

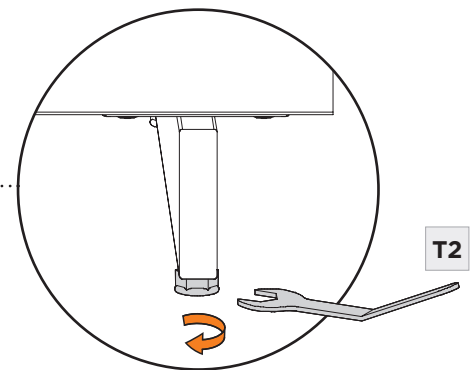

Dial down

For forward facing files, attach **(H5) File Bar Clips** to each end of the **(H4) Small File Bars**. Slide the bars onto the rails so that the **(H5) File Bar Clip** goes into the **groove**.

For **sideways** facing files, **see below**.

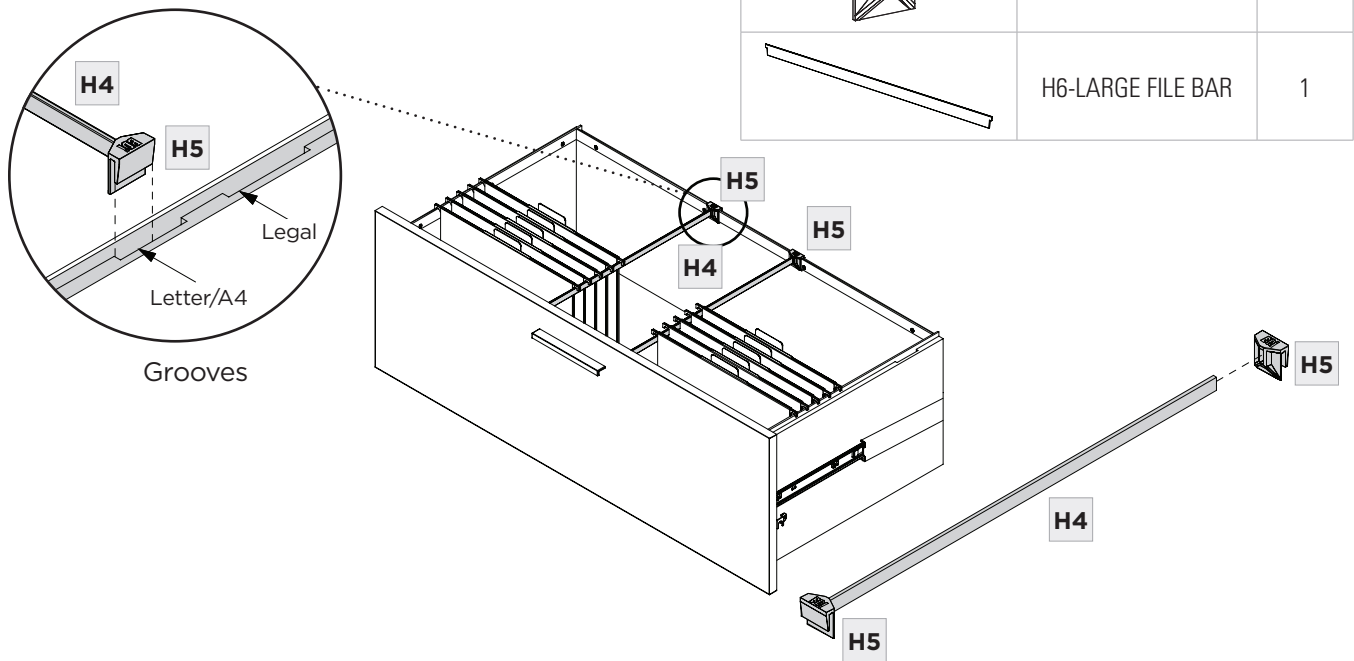

For letter files facing sideways, attach **(H5) File Bar Clip** to both ends of **(H6) Large File Bar** as shown. Place the file bar assembly in the notches located on the left and right drawer side panels. For side facing **legal files**, skip this step altogether and hang file folders directly on front and back rails.

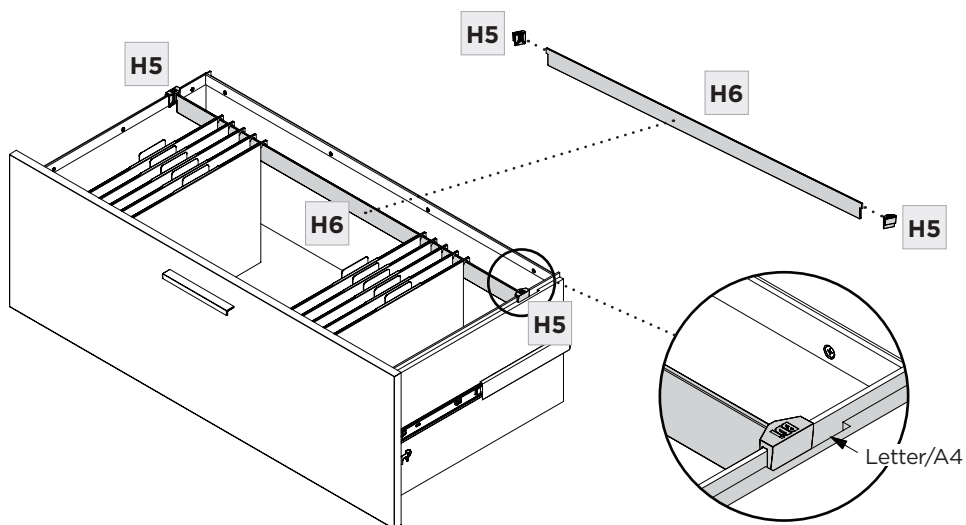

CARE & MAINTENANCE

GLASS

Glass surface is maintained using household glass cleaner and a paper towel or cloth.

SATIN-ETCHED GLASS

This uniquely smooth-to-the-touch glass surface can be regularly maintained using household glass cleaner and a paper towel or cloth. Minor scratches or scuffs not eliminated using paper towel or cloth can usually be removed by using a 'Magic Eraser'. Magic Eraser is a melamine foam product available at any grocery store or home improvement center. Dampen the entire glass surface as well as the Magic Eraser, then rub the entire glass surface in broad, even strokes using moderate pressure. Clean and dry the surface with a paper towel. Check for results and repeat as necessary.

Any scratches or scuffing not eliminated by one of the above methods can often be addressed by 'refreshing' the glass. This is a process that should not be required more than once per 6-12 months. See this brief video for the simple method: www.bdiusa.com/glass

WOOD

Wood surfaces should be cleaned with a slightly damp (not saturated) cloth or paper towel. Do not use glass cleaner on wood. If moisture remains, dry the surface with another cloth. If needed, a gentle non-abrasive cleanser may be used, but be sure to wipe away all cleaner residue and dry the surface with a cloth.

BDI's wood finishes feature natural hardwood solids and veneers. Wood is a product of nature and—unlike man-made materials that can be manufactured to strict and consistent specifications—has natural imperfections that are part of its appeal and character. Every piece of wood differs from every other, even when coming from the very same tree. As such, variation in grain, texture and tone should be expected from one panel or piece of furniture to the next.

While BDI's stained wood finishes are stable in tone & appearance, all finishes are subject to some degree of discoloration with prolonged exposure to direct sunlight. Please take care to avoid positioning your BDI cabinet in any area with extensive direct sunlight. To learn more about the features of natural wood, visit www.bdiusa.com/wood

METAL & PAINTED SURFACES

Surfaces should be cleaned with a slightly damp (not saturated) cloth or paper towel. If moisture remains, dry the surface with another cloth. If needed, a gentle non-abrasive cleanser may be used, but be sure to wipe away all cleaner residue and dry the surface with a cloth.

WARRANTY

BDI warrants to the original purchaser that for the below stated warranty term, BDI will repair or replace any product, part, or component covered by this warranty which fails under normal use as a result of a defect in material or workmanship. BDI will repair or replace the aforementioned product, part or component with a comparable product, part or component. The decision to repair or replace will be at BDI's sole discretion.

BDI Home Theater Furniture, Office Furniture, Modular Systems, Tables and other furniture pieces are warranted for three (3) years from the date of purchase as shown on your sales receipt. The warranty period starts from the date of purchase. This warranty extends only to the original purchasers who acquire new product from BDI Authorized Resellers. Any product, part, or component must have been assembled, installed, used, and maintained according to BDI's published instructions in order to be eligible for warranty coverage. Any modification to the original product voids the warranty.

To view BDI's complete warranty information, visit www.bdiusa.com/warranty

PRODUCT REGISTRATION

Registering your new BDI product allows us to send you important product updates, service information and helpful hints related to your BDI products. Register today, and you will be entered to win free a BINK table from BDI: www.bdiusa.com/register



WARNING

SERIOUS OR FATAL CRUSHING INJURIES CAN OCCUR FROM FURNITURE TIP-OVER. TO HELP PREVENT TIP-OVER:

- Install tip-over restraint.
- Place heaviest items in lower compartments.
- Never allow children to climb or hang on drawers, doors or shelves.
- Never open more than one drawer at a time.

USE OF TIP-OVER RESTRAINT MAY REDUCE—BUT NOT ELIMINATE—THE RISK OF TIP-OVER.



BDIUSA.COM

These distinctive product configurations are protected by US and international patents, trade dress, and/or copyright laws. Sequel & BDI are trademarks of Becker Designed, Inc. All rights reserved. ©2020, BDI | V.11.23.2020

Made in Vietnam.