

# ASSEMBLY INSTRUCTION

ITEM# 3016-90951 5/0 Upholstered Headboard-Bling





3016-90952 5/0 Footboard & Rails-Bling

3016-90967 6/0-6/6 Headboard-Bling

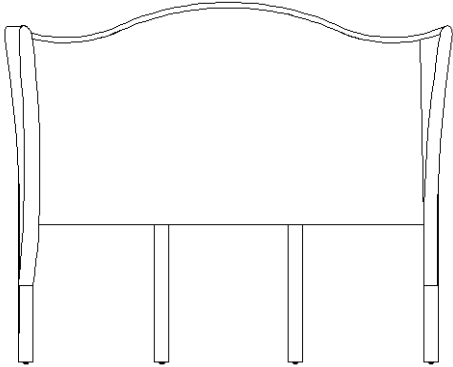
3016-90968 6/6 Footboard & Rails-Bling

**Caution: Please make sure you have all the parts indicated below prior to assembly. This unit is heavy and can best be assembled with the help of two or more persons.**



NO.	HARDWARE LIST		Q'TY
P		ALLEN WRENCH	1
K		BOLT	12
R		LOCK WASHER	12
S		FLAT WASHER	12

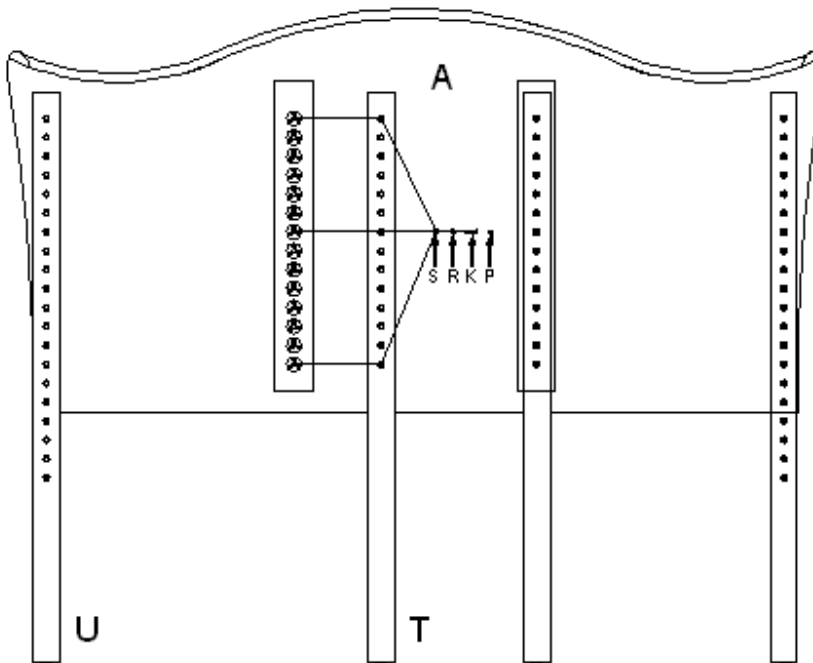

Diagram 1









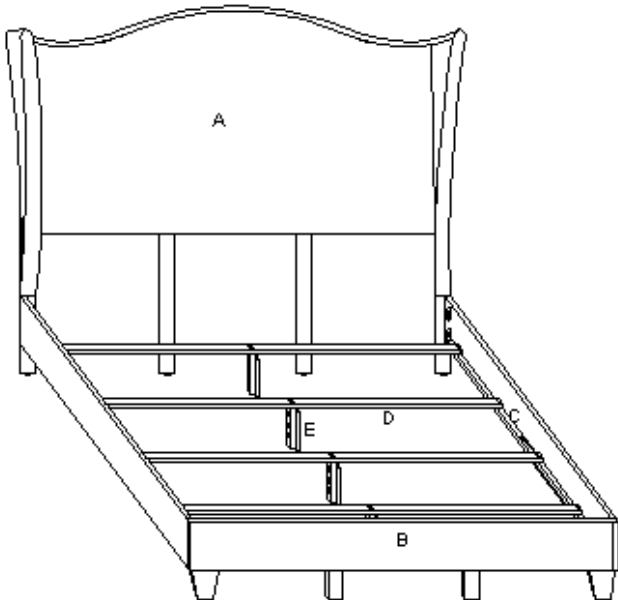



## Assembly steps for headboard:

### 1. Choose the designed height you want on headboard.

2. Attach side posts (U)(golden color) to each side of headboard(A) back using bolts (K), lock washers (R) and flat washers (S). Secure bolt (K) by Allen wrench (P) as shown in diagram 1.
3. Attach middle posts (T) (black color) to center of headboard(A) back using bolts (K), lock washers (R) and flat washers (S). Secure bolt (K) by Allen wrench (P) as shown in diagram 1.

4. Adjust the headboard height by the reversed way as above loosening posts, adjust them and then secure them by the same way as above.



NO.	HARDWARE LIST		Q'TY
F		BOLT	8
G		CURVED WASHER	8
H		NUT	8
I		SPANNER	1
J		SCREW	16
L		4mm ALLEN WRENCH	1
M		40mm BOLT	16
N		1/4" LOCK WASHER	16
O		1/4" FLAT WASHER	16
P		5mm ALLEN WRENCH	1
Q		35mm BOLT	12
R		5/16" LOCK WASHER	12
S		5/16" FLAT WASHER	12

### Assembly steps for bed:

1. Insert 2 bolts (F) into holes of each post on headboard (A) and footboard (B), attach each end of side rails (C) to bolts (F) on posts using curved washers (G), 2 nuts (H) securely with spanner (I), see diagram 2.

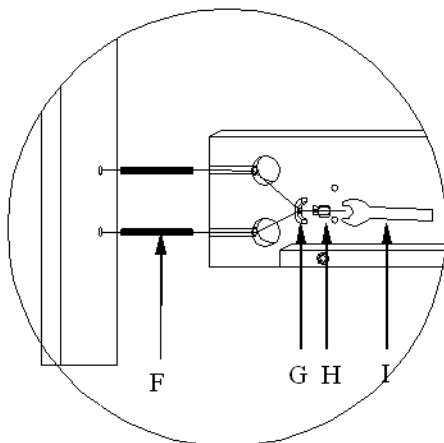

**Diagram 2**

2. Attach center support (E) to slat using 2 bolts (M), 2 lock washers (N) and 2 flat washers (O). Secure bolt (M) by Allen wrench (L) as shown in diagram 3.

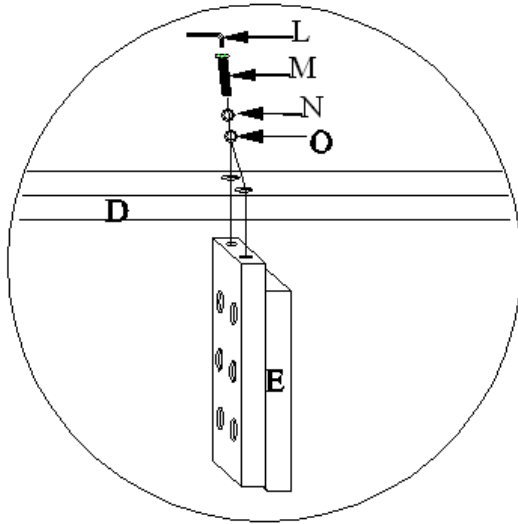

**Diagram 3**

3. Attach slats (D) to side rails (C), align holes pre-drilled on slat with holes on the cleat of side rail (C). Tighten screws on it. See diagram 4.

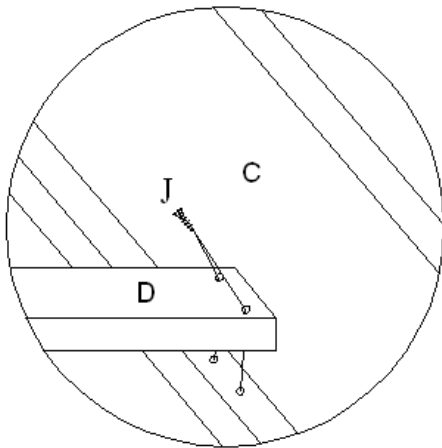

**Diagram 4**

Note: You can change the height of slat by adjusting the height of cleat on side rail as shown in diagram 5, remove bolt (Q), lock washer (R) and flat washer (S) from cleat by turning bolt (Q) with Allen wrench (P) in anti-clockwise direction, adjust cleat to a desired position, and then secure lock washer(R), flat washer(S), bolt (Q) in a clockwise direction by turning with Allen wrench (P).

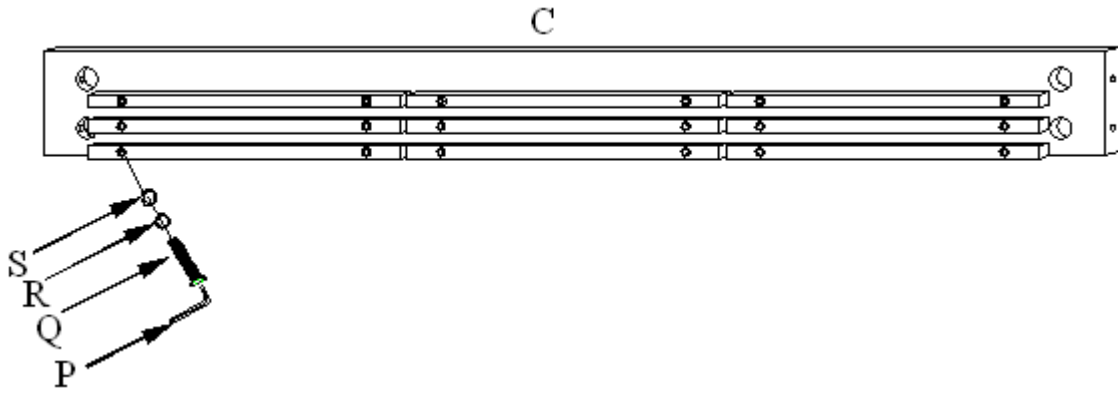

**Diagram 5**

You can adjust the height as shown in diagram 6 to meet your need by the following steps.

1. Unscrew bolts on center support with Allen wrench (L).
2. Adjust the height of center support, align holes on 2pcs of woods and tighten them together with 2 bolts(M), 2 lock washers (N) and two flat washers (O) by using Allen wrench(L).

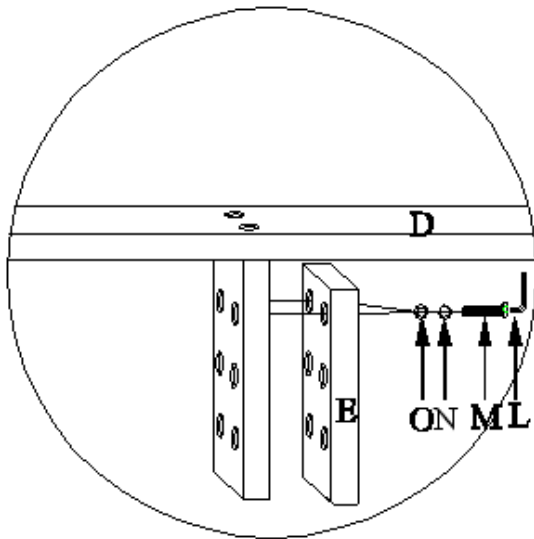

**Diagram 6**

*Cleaning Instruction: Clean finished parts with a damp cloth using a mild dishwashing liquid and water solution.  
Polish the finish with soft cloth and an industry recognized furniture polish.*