

ASSEMBLY INSTRUCTION

ITEM: SS640-RPHZ1-088 Torres Right One Arm Power Headrest Recliner

Thank you for purchasing this quality product. Be sure to unpack carefully looking for small parts which may have come loose during shipment. Read all instruction and study the drawing carefully before starting the assembly process.

Inside the carton you will find a red plastic bag that have the raf recliner's wing in it. Remove the wings from the plastic bag and set them aside to be used in assembly and installation

CAUTION: Make sure to read the instructions below before assembling your double power raf recliner. We suggest two people be used in the assembly of your double power raf recliner.

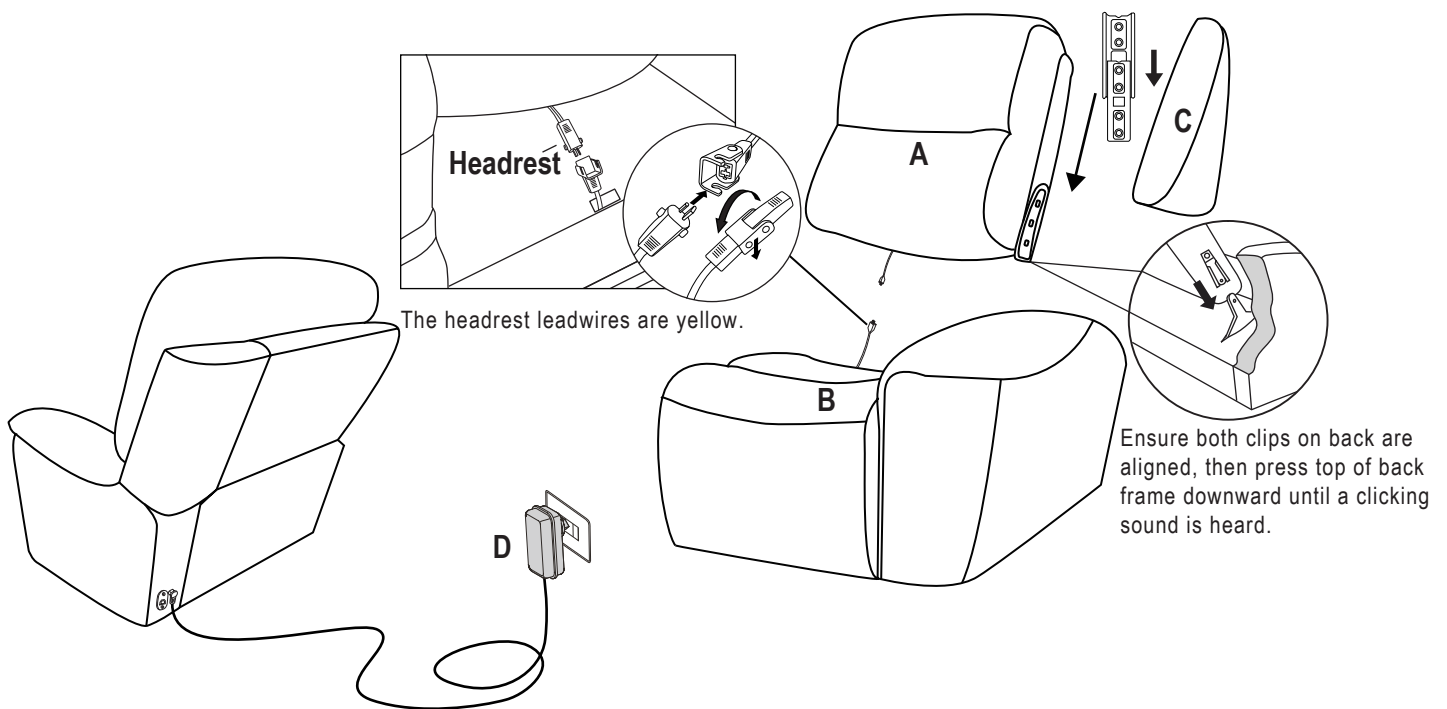
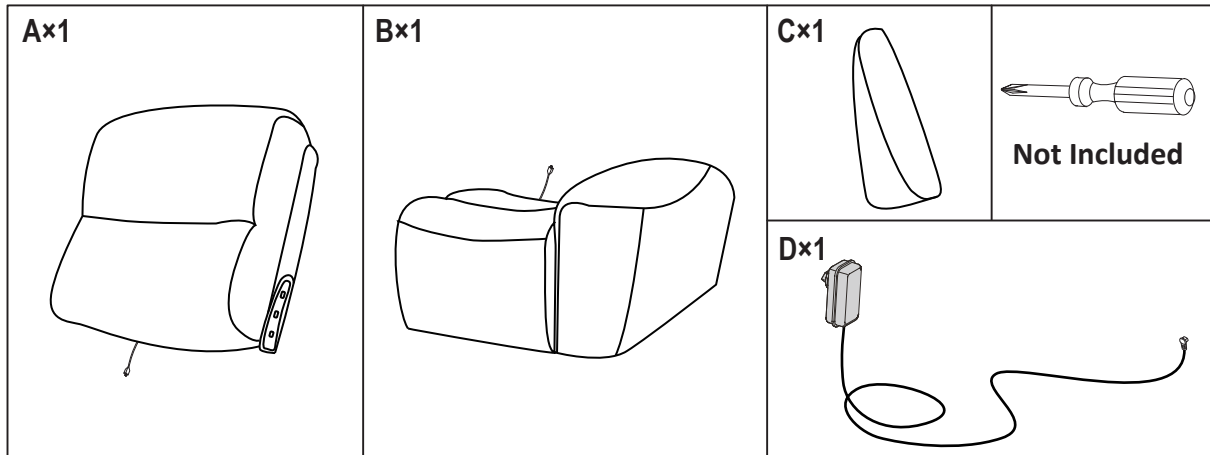

You can connect two or more recliners by connecting each position with male and female buckle as Figure A illustrated.

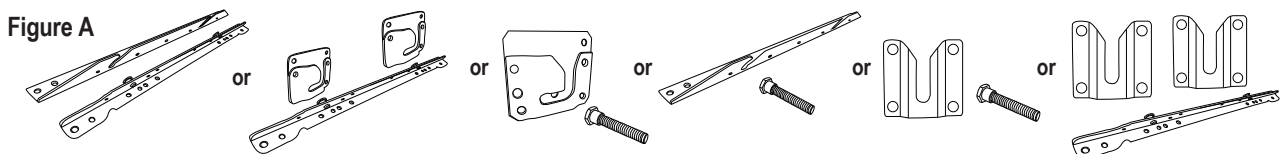

Notes: Do Not plug the power cord into a power outlet until your furniture is fully assembled and in place. To help prevent shock and or damage to your product only plug the power cord into a grounded outlet.

IMPORTANT NOTE

- To avoid any risk of suffocation to children or pets, dispose of all plastic bags immediately.
- To ensure proper performance, occasionally check for loose screws and tighten as needed.

CAUTION: Read the important instructions below before operating your power mechanized equipment
Do not allow children to play on or operate this power mechanized equipment

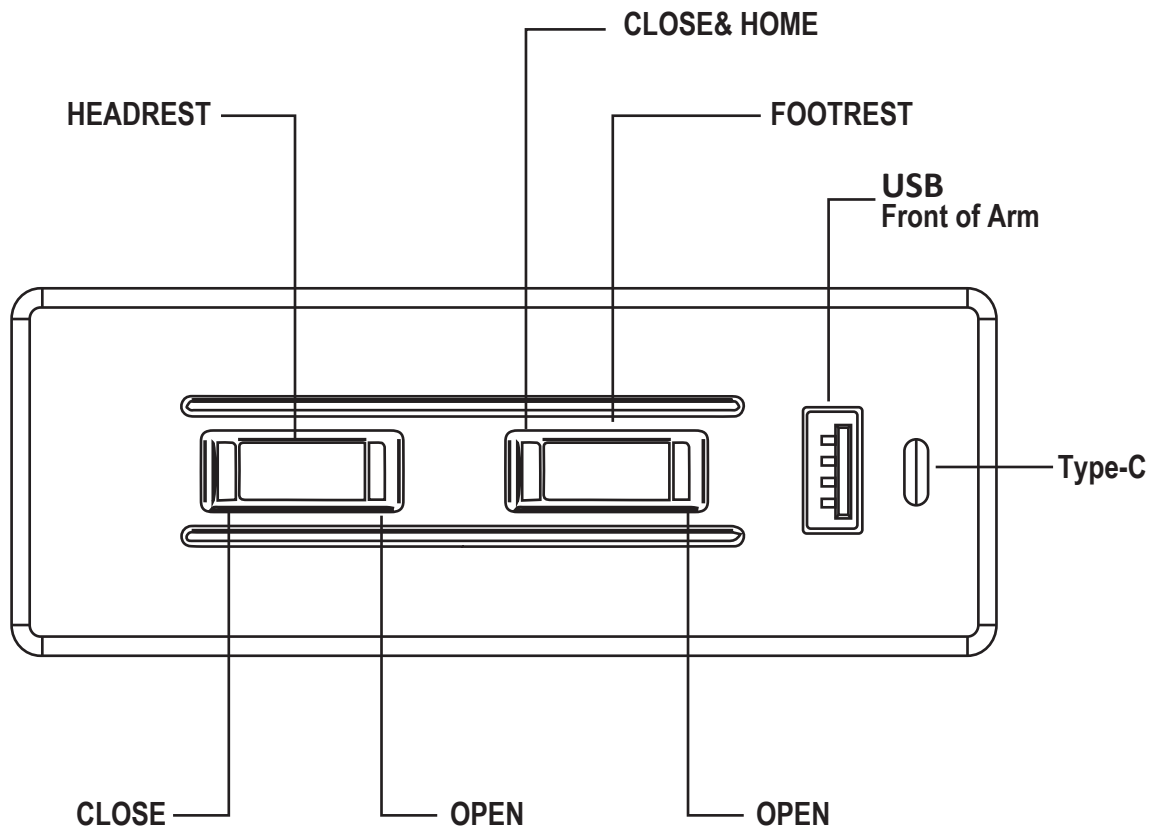

Care should always be taken to assure there is nothing in the path of the mechanism before and during operation.

To recline: Sit on the furniture, and press the front of the button closest to the footrest to smoothly raise the footrest and recline to any position. To lower the footrest and return to an upright position, press the back side of the button closest to the footrest.

To adjust headrest: Press the front of the button closest to the backrest to smoothly raise and adjust the headrest to any position. To lower the headrest and return it to its original position, press the back side of the button closest to the backrest.

To close all: To simultaneously return the headrest, footrest, and lumbar support to their original positions, press and hold the back side of the button closest to the footrest.

NOTE: This device complies with part 15 of the FCC rules. Operation is subject to the following two conditions: (1) this device may not cause interference, and (2) this device must accept any interference, including interference that may cause undesired operation of the device. Modifications not approved by the party responsible for compliance could void user's authority to operate the equipment.

Customer Service

If you have any questions regarding the use of this unit, or find that your unit needs service, please contact your retailer.

Product Protected By Following Patents:
Patented Articulating Power Headrest
US Patent: 10,736,423